

**Dimensions for MHR5310 - Triangular flange mounting with a sprung shaft**

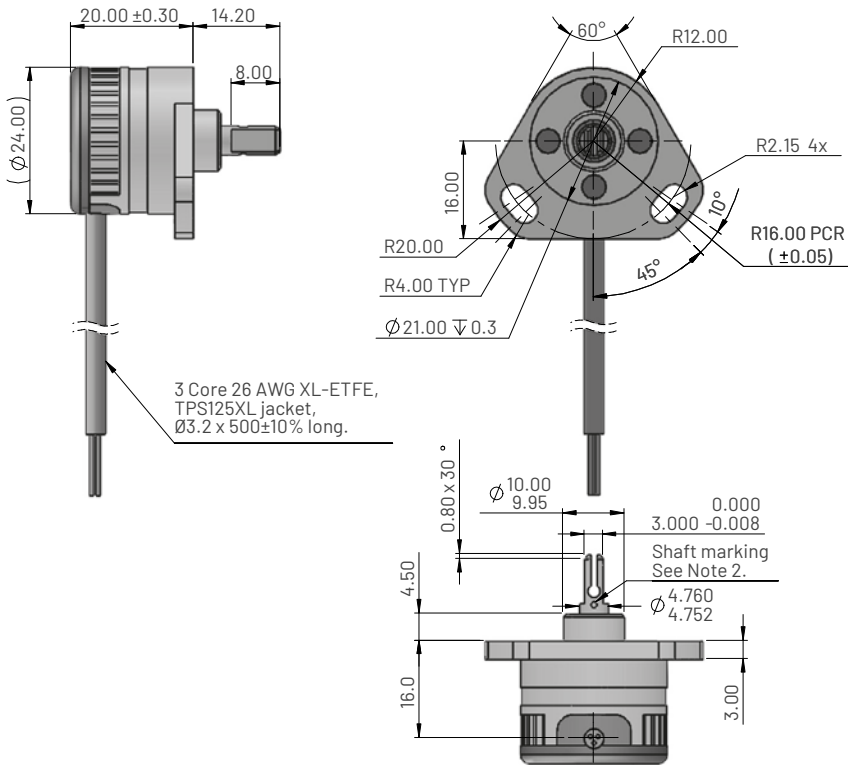

**Driving side detail**

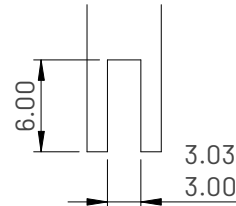

**Ordering code**

**MHR5310 XV-XXX**

Output direction (viewed on shaft)

C = Clockwise

A = Anticlockwise

Electrical angle in degrees

**Dimensions for MHR5320 - Triangular flange mounting with a round shaft**

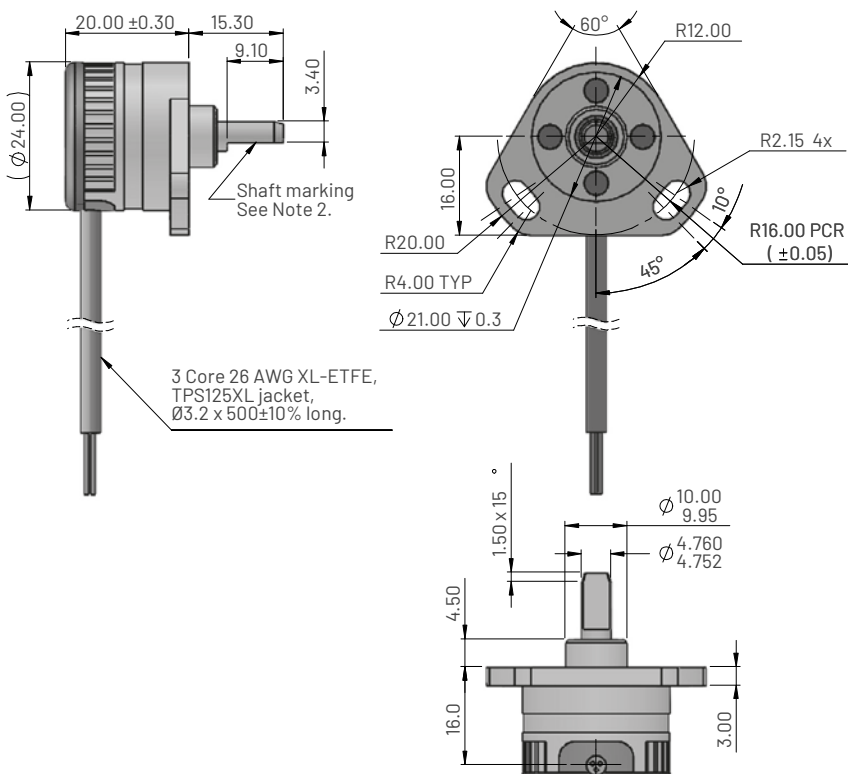

**Ordering code**

**MHR5320 XV-XXX**

Output direction (viewed on shaft)

C = Clockwise

A = Anticlockwise

Electrical angle in degrees

**Dimensions for MHR5330 - Triangular flange mounting with a blade shaft**

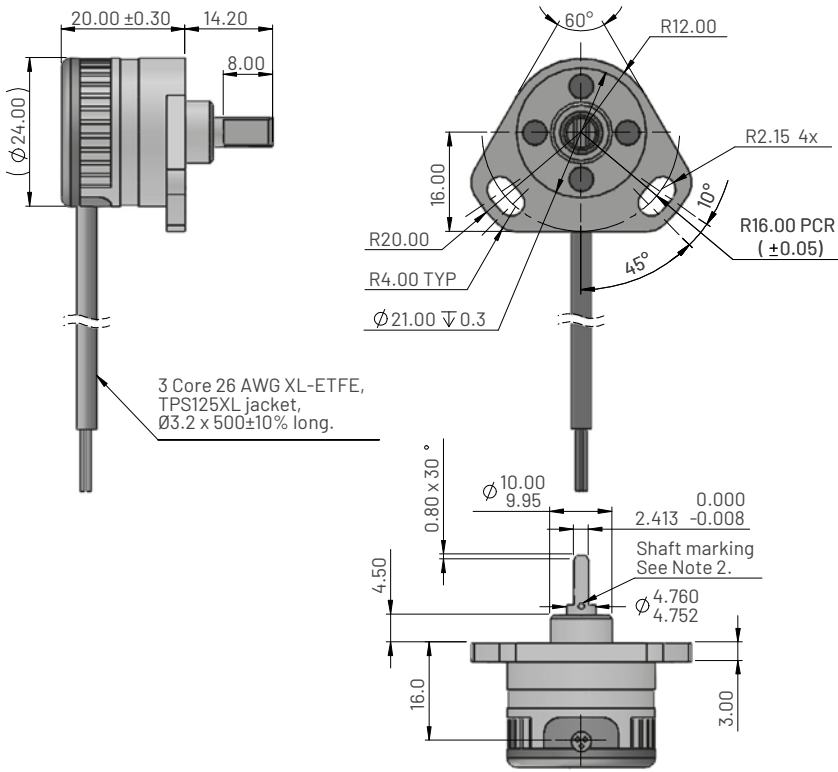

**Driving side detail**

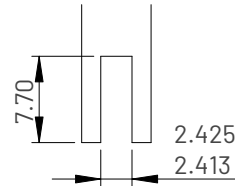

**Ordering code**

**MHR5330 XV-XXX**

Output direction (viewed on shaft) ↙

C = Clockwise

A = Anticlockwise

Electrical angle in degrees \_\_\_\_\_

**Electrical and mechanical specification for MHR5300 Series**

Input specification

Supply voltage (Vs)	5.0±10% regulated	8 to 30 unregulated	VDC
Over voltage protection	Up to 50		VDC
Supply current	<15		mA
Reverse polarity protection	Up to -10		VDC
Power on settlement time	<100		ms
Input voltage rise time	0.25 minimum		V/ms

Output specification

Output type	Analogue voltage		
Output direction	Clockwise or anticlockwise (specified at time of order)		
Voltage output (Vout)	0-Vs (+5)	0 - 5.0	VDC
Monotonic range	Ratiometric with Vs	<0.01% FS	
	Linear Range (see note 5)		
Load resistance	>10K		Ohms
Output noise	<5		mV RMS

Performance specification

Measurement range	20 to 360±2 in 1° increments		°
Resolution	0.025		% of measurement range
Non-linearity (Note 4)	<±0.25		%FS
Temperature coefficient (Vout)	<±0.003	<±0.011	%FS/°C
Update rate	500 Nom		Hz
Max operating speed	600		RPM

General specification

Weight (approx.)	30		grams
Protection/sealing	Electronic housing IP68 and IP69K		
Life (shaft in bush bearing)	>500 million cycles		dependant on environment
Dither life	Contactless - no degradation due to shaft dither		
Operational temperature	-40 to +150	See de-rating graph	°C
Storage temperature	-55 to +150		°C
Materials	Case: Glass filled polymer, Top cap: GF polymer, Shaft: Stainless steel 316		

**Notes**

1. Incorrect wiring may cause internal damage.
2. When shaft marking is facing cable exit, instrument is mid-travel (2.5V output).
3. Do not operate between 5.5V and 8V.
4. Non-linearity is calculated from least squares best fit method over the Linear Range.
5. Linear Range = Measurement range x 0.995 Nom.
6. Due to hall effect technology used in this device, ferrous materials and magnetic fields close to the sensor may influence output.
7. General dimension tolerance is  $\pm 0.25$ .

**Electrical connections (see note 1)**

Wire Colour	Function
Red	Supply Voltage (Vs)
White	Output Voltage (Vout)
Black	Ground

**Typical output**

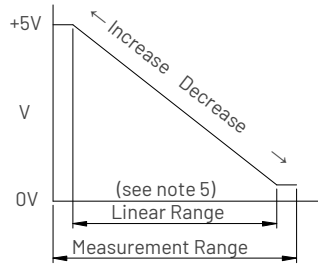

**Input voltage de-rating graph**

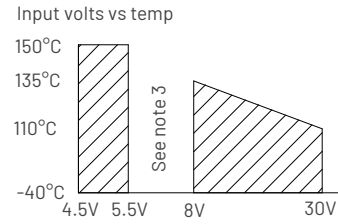

**Accessories**

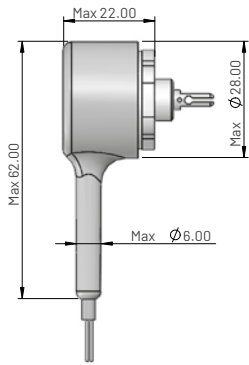

Boot dimensions when fitted  
(Boot supplied seperately)

**Shrink boot**

Ordering code: JN025-002

Material
EVA adhesive lined fluoroelastomer lipped boot