

Dimensions for MHR5610 - Triangular flange mounting with a sprung shaft

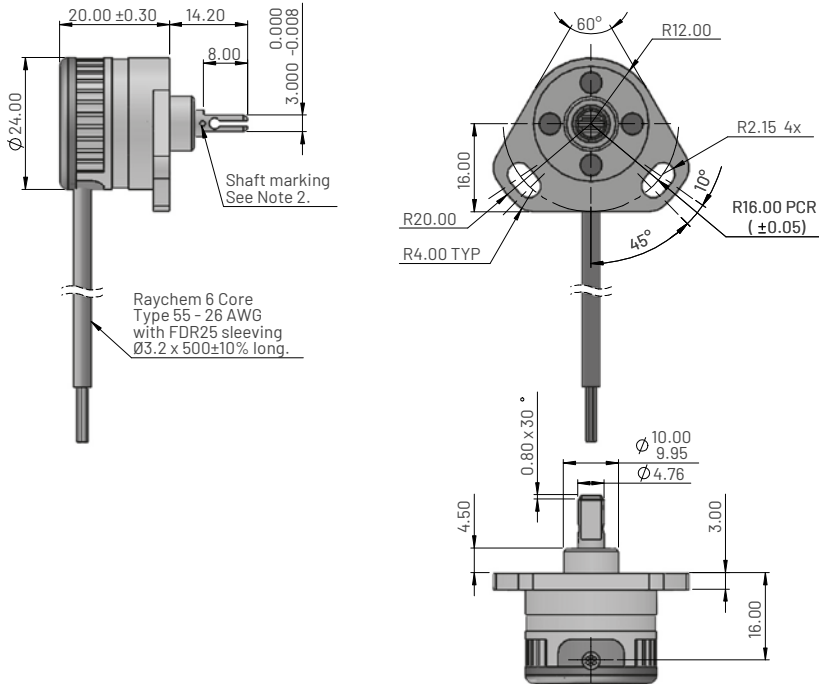

Driving side detail

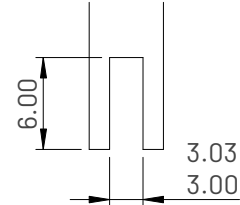

Ordering code

MHR5610 XV-XXX

Output direction (viewed on shaft)

- C = Clockwise
- A = Anticlockwise
- D = Channel 1 output anticlockwise
Channel 2 output clockwise

Electrical angle in degrees

Dimensions for MHR5620 - Triangular flange mounting with a round shaft

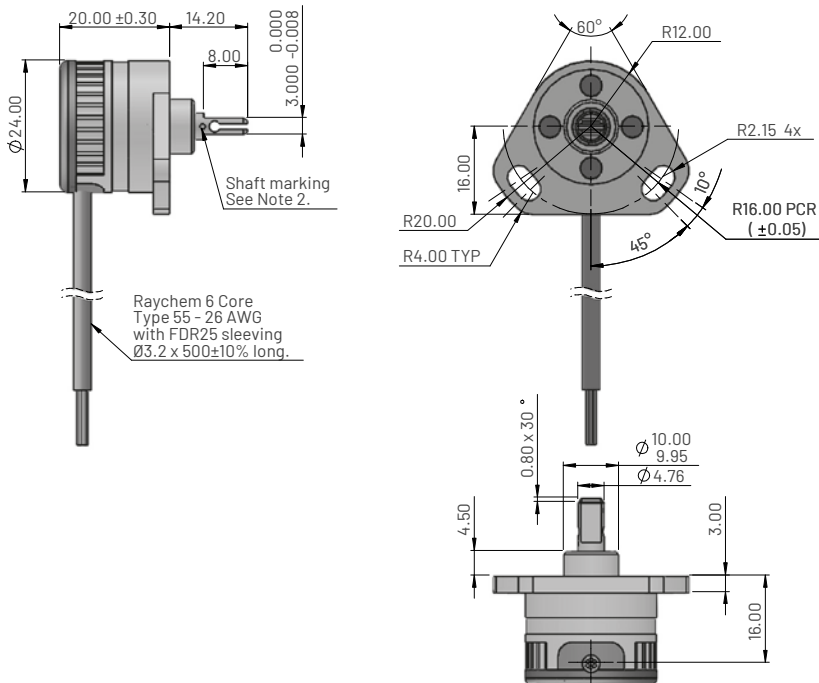

Ordering code

MHR5620 XV-XXX

Output direction (viewed on shaft)

- C = Clockwise
- A = Anticlockwise
- D = Channel 1 output anticlockwise
Channel 2 output clockwise

Electrical angle in degrees

Dimensions for MHR5630 - Triangular flange mounting with a blade shaft

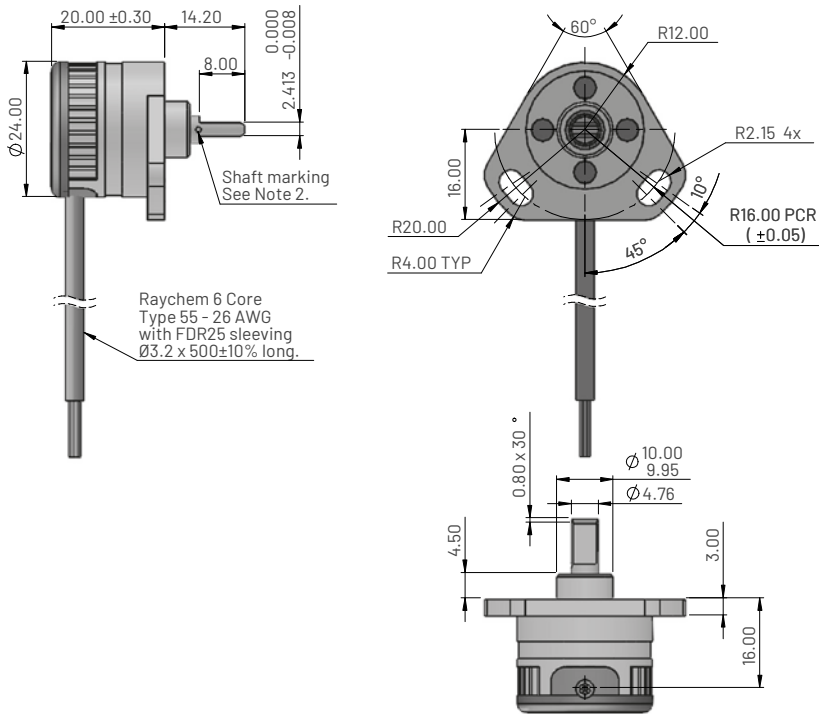

Driving side detail

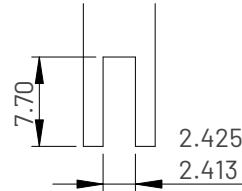

Ordering code

MHR5630 XV-XXX

Output direction (viewed on shaft)

- C = Clockwise
- A = Anticlockwise
- D = Channel 1 output anticlockwise
Channel 2 output clockwise

Electrical angle in degrees

Electrical and mechanical specification for MHR5600 Series

Input specification			
Supply voltage (Vs)	5.0±10% regulated	8 to 30 unregulated	VDC
Over voltage protection	Up to 50		VDC
Supply current	<15		mA
Reverse polarity protection	Up to -10		VDC
Power on settlement time	<100		ms
Input voltage rise time	0.25 minimum		V/ms
Output specification			
Output type	Analogue voltage		
Output direction	Clockwise or anticlockwise (specified at time of order)		
Voltage output (Iout)	0-Vs (+5)	0 - 5.0	mA
Line regulation	Ratiometric with Vs	<0.01	%FS
Monotonic range	Linear Range (see note 6)		
Load resistance (max)	>10K		Ohms
Output noise	<5		mV RMS
Performance specification			
Measurement range	20 to 360 in 1° increments		°
Resolution	0.025		% of measurement range
Non-linearity (Note 4)	<±0.25		%FS
Temperature coefficient (Vout)	<±0.003	<±0.011	%FS/°C
Update rate (nominal)	500		Hz
Max operating speed	600		RPM
General specification			
Weight (approx.)	30		grams
Protection/sealing	Electronic housing IP68 and IP69K		
Life	>500 million cycles		dependant on environment
Dither life	Contactless - no degradation due to shaft dither		
Operational temperature	-40 to +150	See de-rating graph	°C
Storage temperature	-55 to +150		°C
Materials	Case: Aluminium 6082, Top cap: GF polymer, Shaft: Stainless steel 316		

Notes

1. Incorrect wiring may cause internal damage.
2. When shaft marking is facing cable exit, instrument is mid-travel (2.5V output).
3. Do not operate between 5.5V and 8V.
4. Non-linearity is calculated from least squares best fit method over the Linear Range.
5. Phasing for the MHR5610 DV-XXX option is at mid-travel only.
6. Linear Range = Measurement range x 0.995 Nom.
7. Due to hall effect technology used in this device, ferrous materials and magnetic fields close to the sensor may influence output.
8. General dimension tolerance is ± 0.25 .

Electrical connections (see note 1)

	Wire Colour	Function
Channel 1	Red	Supply Voltage (Vs)
	White	Output Voltage (Vout)
	Black	Ground
Channel 2	Blue	Supply Voltage (Vs)
	Yellow	Output Voltage (Vout)
	Green	Ground

Typical output

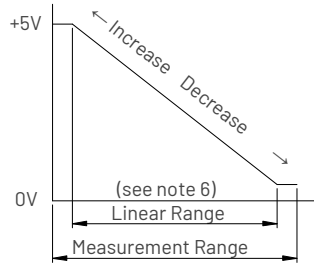

Input voltage de-rating graph

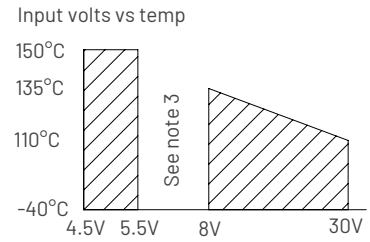

Accessories

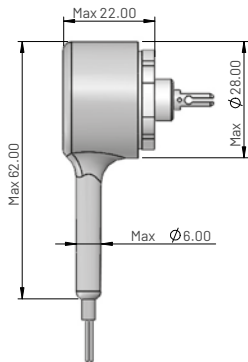

Boot dimensions when fitted
(Boot supplied separately)

Boot
Part No: JN025-002

Material
Polyolefin